



SINGH ISOTECH

SINCE-1996

ELECTRICAL CONSULTANTS X RISK ASSESSMENT X PANEL BUILDERS



www.singhisotech.com



About Us

A 26-year-old firm specializing in electrical consulting, energy auditing, and electrical & fire safety auditing. The firm is certified by BEE (Bureau of Energy Efficiency), ISO 50001, ISO 45001, and MSME NSIC, and has won multiple awards for its outstanding auditing services.

Directors



R.V Singh (65 Years)
45+ Years of Experience in Electrical Projects.

Experience Prior to Business:-

8 Years in ITDC (Indian Tourism Development Corporation) as Project Manager

2 years at Garden Estate Gurgaon as Projects Head

9 Years in DLF Ltd. Resigned as Chief Project Manager

Projects Executed: Ashok Yatri Nivas, Hotel Ashoka (Delhi & Agra), Hotel Samrat, Developed DLF Ph-1,2,3,4,5, DLF Green Valley Farms, Dilshad Garden & many more



Vishal Singh (32 Years)

Proud BNI Member (5 Years)

10+ Years of Experience in Electrical Consultancy

MBA from **S P Jain School of Global Business**

Electrical Engineer from **BITS-Pilani**



Why Us?

**PAN INDIA
PRESENCE
(28 STATES)**



**SHORT
PROJECT
TIMELINES**

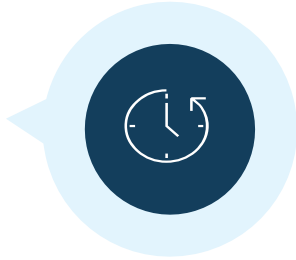

**IN-HOUSE
INDUSTRY
EXPERTS &
CONSULTANTS**



**QUALITY
ASSURANCE**



**HI-END
INSTRUMENTS &
NABL LAB
ACCREDITATIONS**



**PROVEN
TRACK
RECORDS**



**500+
DELIGHTED
CLIENTS**



INDUSTRIAL FOOTPRINTS



ACHIEVEMENTS & HONORS



BUSINESS VERTICALS

Singh Isotech Pvt. Ltd. encompasses five major business divisions.



SAFETY & RISK MANAGEMENT

01

- Electrical Safety & Gap Audits
- Energy Audits
- Fire Safety Audits
- Structural Audits
- Process Audits
- Sustainability Audits
- Root Cause Analysis Audits



ELECTRICAL DESIGN & CONSULTANCY

02

- Electrical Design Consultancy
- Lightning Protection Designs
- Electrical & Fire Designs
- Arc Flash Design & Studies
- Fire & Gas Mapping Studies
- Ergonomics Studies
- Industrial Hygiene Studies



ELECTRICAL TURNKEY PROJECTS

03

- Turnkey Projects- Elect. & Fire
- Risk Assessment & mitigation
- Cost Effective Execution
- Regulatory Approvals & Permits
- End to End Project Management



HT-LT PANELS MANUFACTURERS

04

- Main LT & Sub-Panels
- All Types- PLC, MCC, APFC, VFD, SOLAR, etc.
- High Quality Components
- Extended Warranties
- Minimal Delivery Time
- Onsite Installation Services



ELECTRICAL GOODS TRADERS

05

- 45+ Brands Available
- Special Discounted Rates
- Extended warranties
- Brands: Polycab, Havells, Norisys, GM, Goldmedal, L&T, Wipro etc.

SAFETY & RISK MANAGEMENT AUDITS



**ENERGY
AUDIT**

**ELECTRICAL
AUDIT**

**FIRE
AUDIT**

**WATER
AUDIT**

**HSE
AUDIT**

**STRUCTURAL
AUDIT**

**VIRTUAL
AUDITS**

**LIGHTNING
PROTECTION
AUDIT**

**SUSTAINABLE
AUDIT**

**GREEN
AUDIT**

**INDUSTRIAL
HYGIENE
AUDIT**

**HVAC &
PLUMBING
AUDIT**

**ERGONOMICS
AUDIT**

**WASTE
MANAGEMENT
AUDIT**

COMPLETE ENGINEERING SERVICES AUDITS

RISK ASSESSMENT STUDIES/ TRAININGS

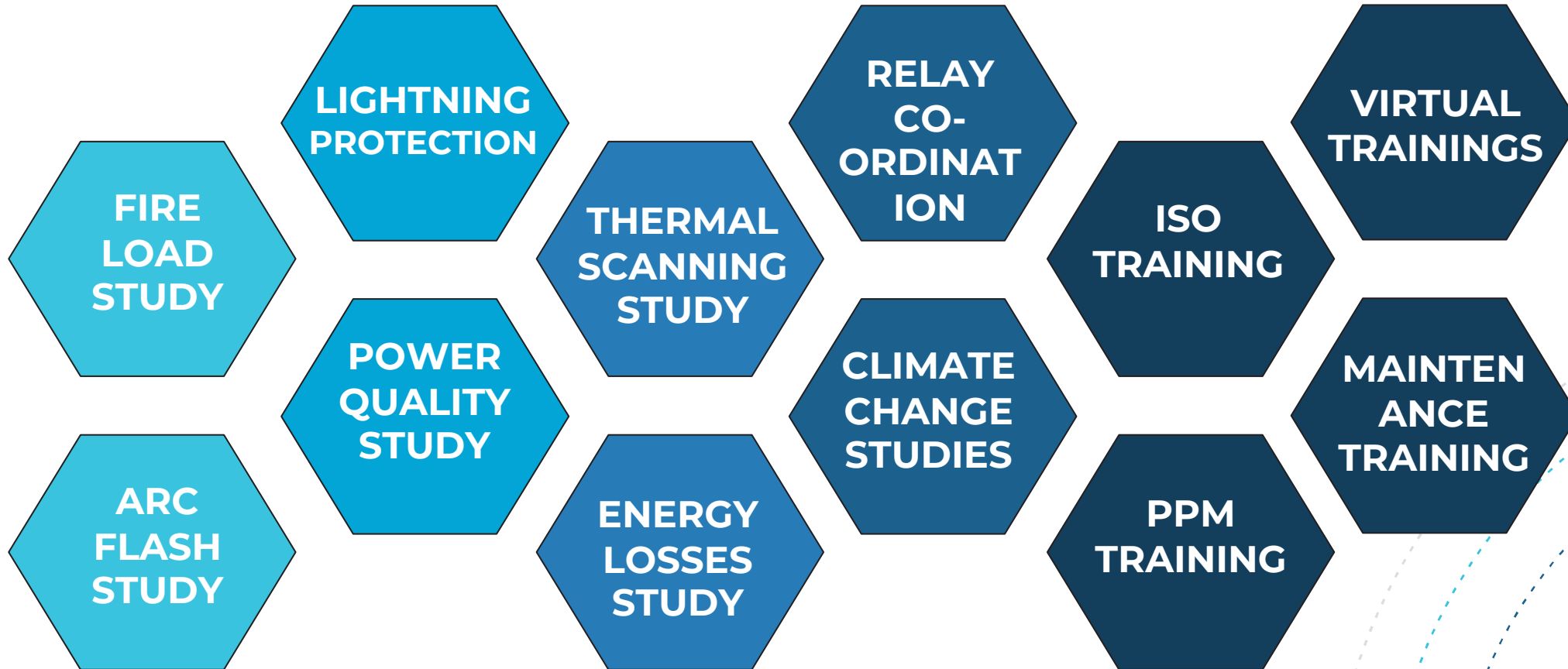

COMPLETE RANGE OF CUSTOMIZED STUDIES & TRAININGS

DESIGN & CONSULTANCY SERVICES

- ✓ Electrical Design Consultancy
- ✓ Lightning Protection Design
- ✓ HT / LT Panel Designs
- ✓ Substation Design Consultancy
- ✓ Earthing System Designs
- ✓ Environmental Design Services
- ✓ MEP Design Review- Gap Analysis

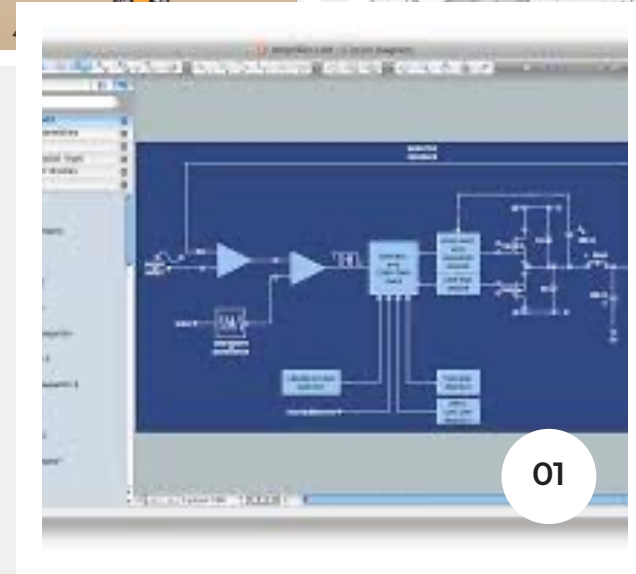
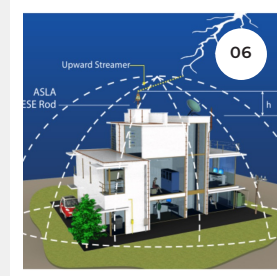
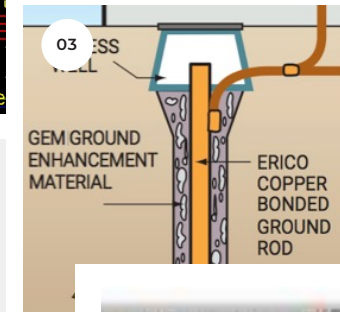
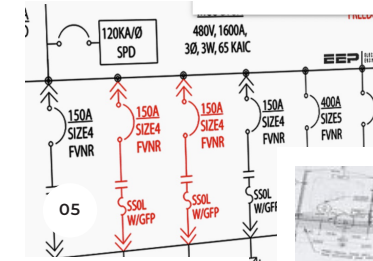
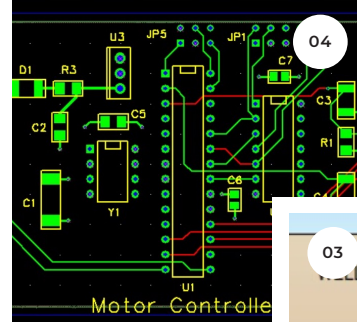

02

01

04

06

★ RECOMMENDED ★

**BEST
SELLING
SERVICES**



ELECTRICAL SAFETY AUDIT

- Ensure your premises are 100% electrically safe by evaluating and maintaining the existing electrical design & systems.

ENERGY AUDIT

- Optimize energy usage, reduce bills by up to 40%, and enhance equipment efficiency through an energy audit.

FIRE AUDIT

- Ensure comprehensive fire safety, detection, and firefighting systems through a thorough fire audit.

TRANSFORMER/ VCB/ PANELS SERVICING/ TESTING

- Efficient servicing for transformers (Dehydration, Filtration), VCBs, panels, and various electrical items to maintain top-notch performance.

TRAIN YOUR MAINTENANCE TEAM

- Empower your maintenance team with a comprehensive 1-day on-site training and monthly maintenance checklist.



PAN INDIA PRESENCE

- DELHI NCR
- LUCKNOW
- AHMEDABAD
- JAIPUR
- BHOPAL
- RAIPUR
- MUMBAI
- CHENNAI
- BANGALORE
- HYDRABAD
- KOLKATA
- JAMMU

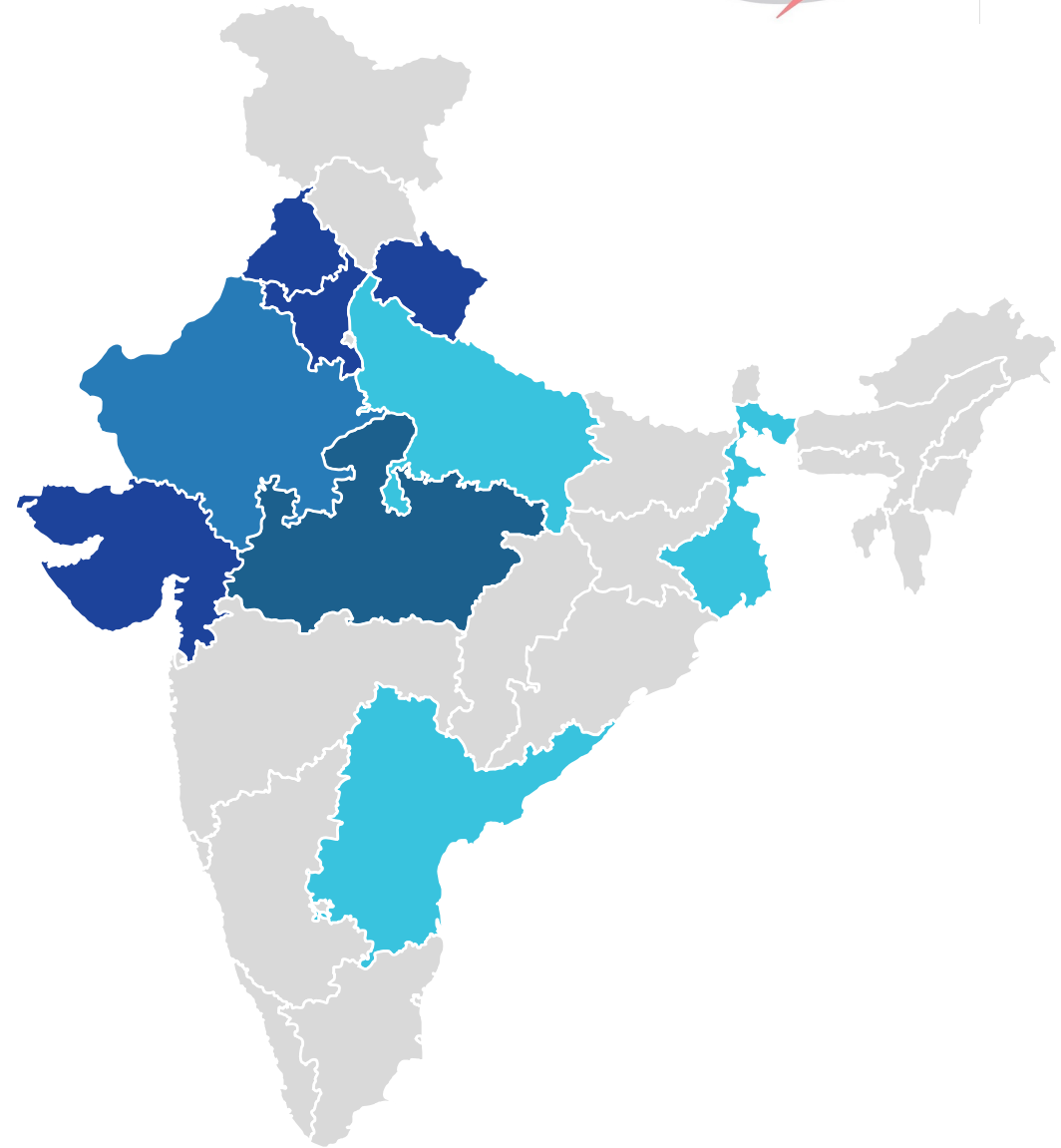

Contact Detail

SINGH ISOTECH PVT. LTD.

ELECTRICAL CONSULTANTS X RISK ASSESSMENT X PANEL BUILDERS



PHONE

Phone : +91 9999 888 902

Phone : +91 9871 659 963



ADDRESS

HQ: GURUGRAM

A-335A Sushant Lok-1

A Block, Gurugram, Haryana



EMAIL

mail@singhisotech.com

sales@singhisotech.com



BROCHURE



PHONE CALL



WHATSAPP

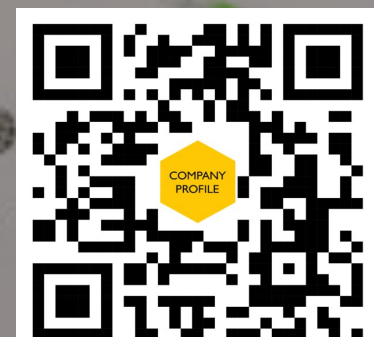

COMPANY PROFILE